

Mouldings

■ = FJP
 ● = CLEAR
 M = MDF
 * = FJP + CLEAR
 SHADING = IN STOCK

CASING

<p>8730 CASING WM315 11/16 x 2 1/2</p>	<p>CR373 CRAFTSMAN 11/16 x 3 1/2</p>	<p>8731 CASING WM448 11/16 x 3 1/2</p>	<p>S-15 FJP 1 1/8 x 7 1/4</p>
<p>8627 CASING WM472 9/16 x 2 1/2</p>	<p>* 8754 CASING WM444 11/16 x 3 1/2</p>	<p>8308 2 ROUND CORNER CASING WM412 11/16 x 3 1/2</p>	
<p>8725 CASING 11/16 x 2 1/2</p>	<p>* 3 1/2 JALCO CASING 11/16 x 3 3/8</p>	<p>CR670 HARBOR CLASSIC 3.5" CASING 3/4 x 3 1/2</p>	
<p>8753 CASING WM361 11/16 x 2 1/2</p>	<p>CR390 VICTORIAN CASING 3/4 x 3 5/16</p>	<p>B225 MARBLEHEAD CASING 11/16 x 3 1/2</p>	
<p>8710 CASING WM351 11/16 x 2 1/2</p>	<p>ANDOVER CASING 15/16 x 3 1/2</p>	<p>B200 WINDSOR CASING 1 1/16 x 3 1/2</p>	
<p>* 2 1/2 JALCO CASING 11/16 x 2 1/2</p>	<p>EXOTICA CASING 1 1/16 x 3 1/2</p>		
<p>CR398 HARBOR CLASSIC 2.5" CASING 3/4 x 2 1/2</p>			
<p>CR369 ANDOVER CASING 1 1/16 x 4 1/8</p>	<p>CR692 ADAM CASING 3/4 x 4 1/2</p>		
<p>* B100 BELLY BAND CASING 1 1/16 x 4 1/4</p>	<p>FLUTED CASING 1 x 4 1/2</p>		
<p>CR691 HARBOR CLASSIC 4.5" CASING 3/4 x 4 1/2</p>	<p>CR393 QUEEN ANNE CASING 3/4 x 5</p>		

APRON

8642 APRON
5/8 x 3 1/2

1269 APRON
5/8 x 2 1/2

8645 APRON
5/8 x 2 1/2

BACK BAND

CR304 TORUS BACK BAND
1 9/16 x 1 1/8

CR303 REVIVAL BACK BAND
1 5/16 x 1 3/16

CR377 QUEEN BACK BAND
1 3/16 x 1 13/16

GLASS BEAD

8590
3/8 x 1/2

B672 HARBOR BEAD
3/8 x 7/8

5/8" x 3/4"

8767 SCREEN STOCK
1 1/16 x 1 3/4

PANEL WALLBOARD and TILE BOARD

PANEL MOLD
9/16 x 1 1/2

8451
7/16 x 1 1/8

8161
3/8 x 1

B636 PANEL
5/8 x 2 1/4

8138 PANEL WM978
3/8 x 1 3/4

Mouldings

■ = FJP
 ● = CLEAR
 [M] = MDF
 * = FJP + CLEAR
 SHADING = IN STOCK

BASE

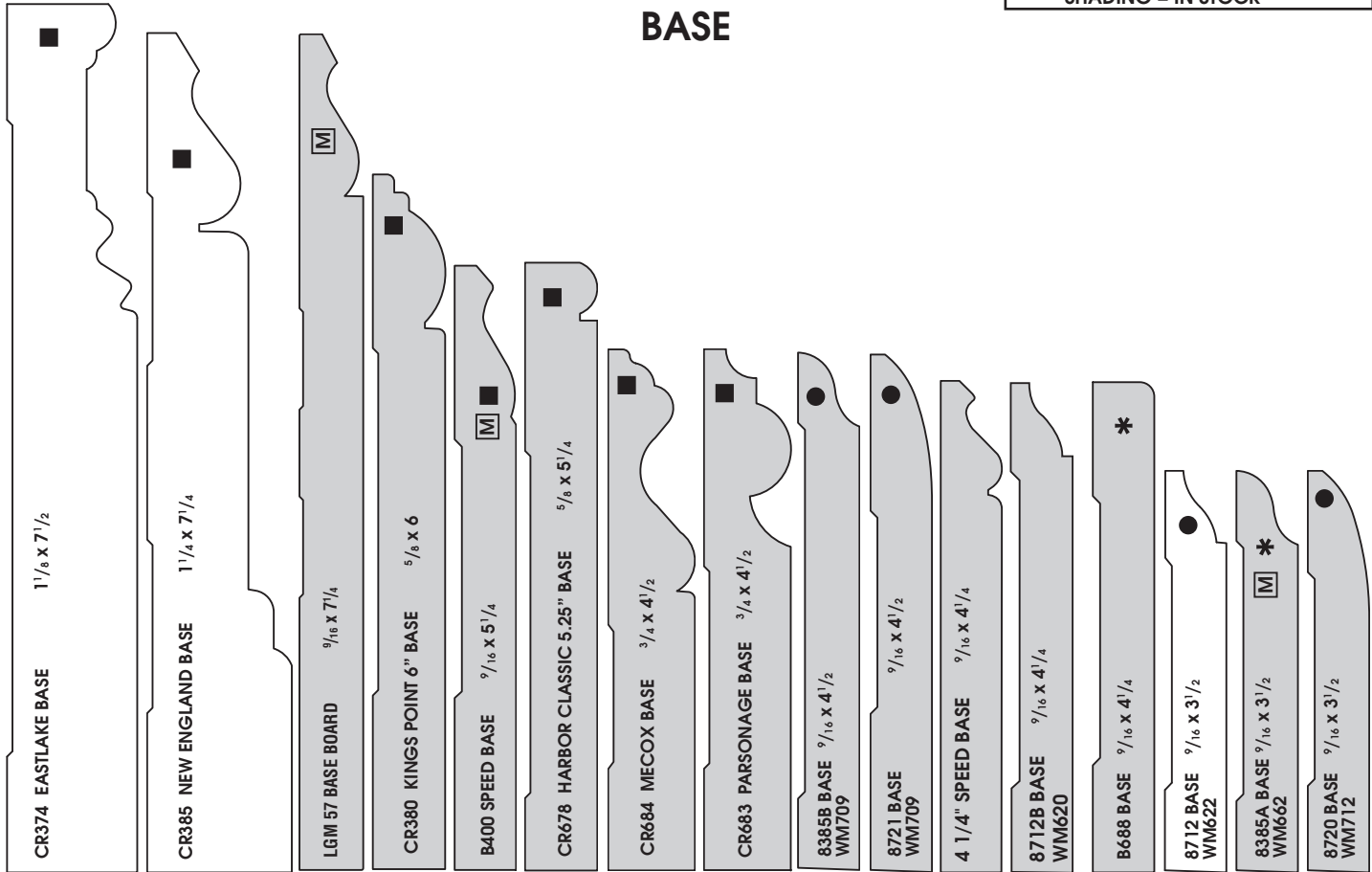

STOP

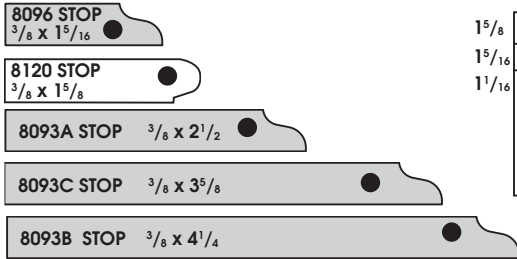

BALUSTER STOCK

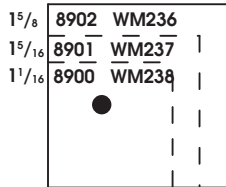

OAK NOSING

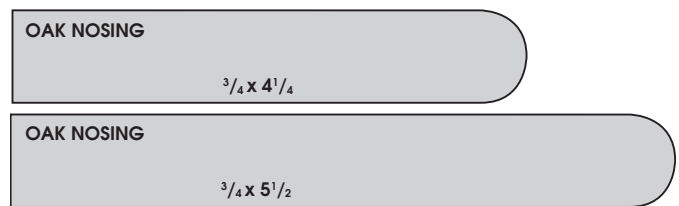

STOOL CAP

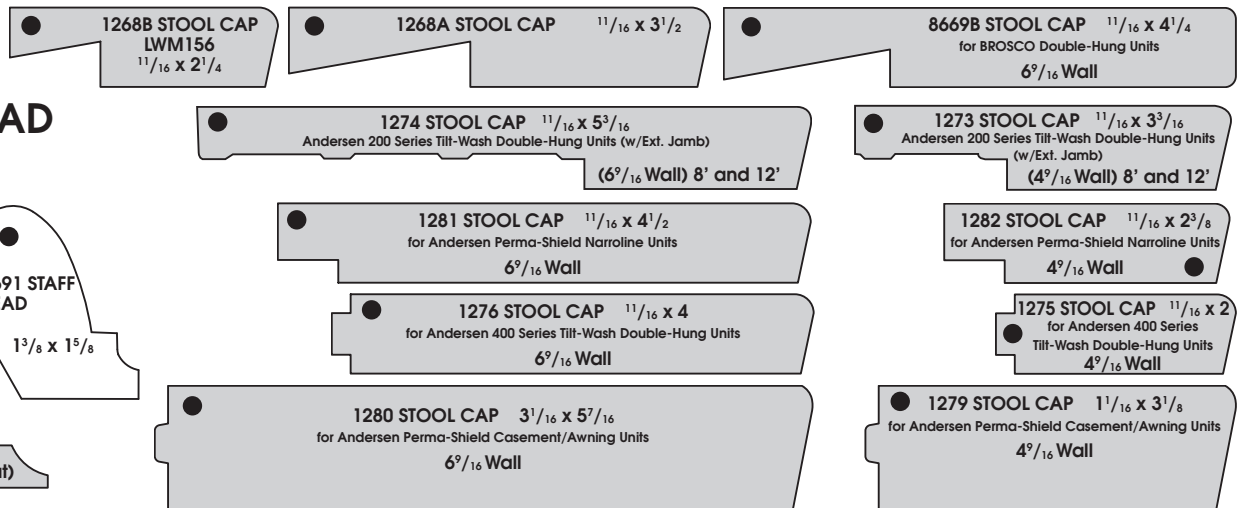

STAFF BEAD

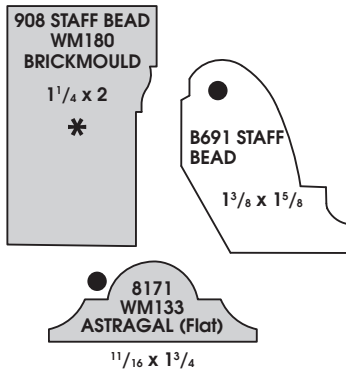

Mouldings

■	= FJP
●	= CLEAR
□	= MDF
*	= FJP + CLEAR
SHADING = IN STOCK	

CORNICE

APPROXIMATE COVERAGES

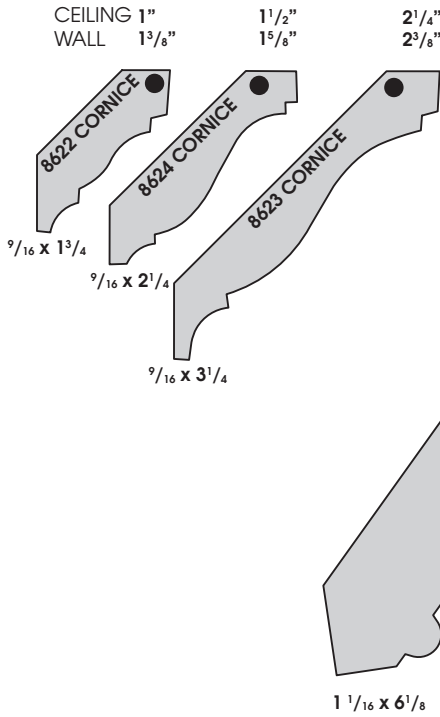

CROWN

APPROXIMATE COVERAGES

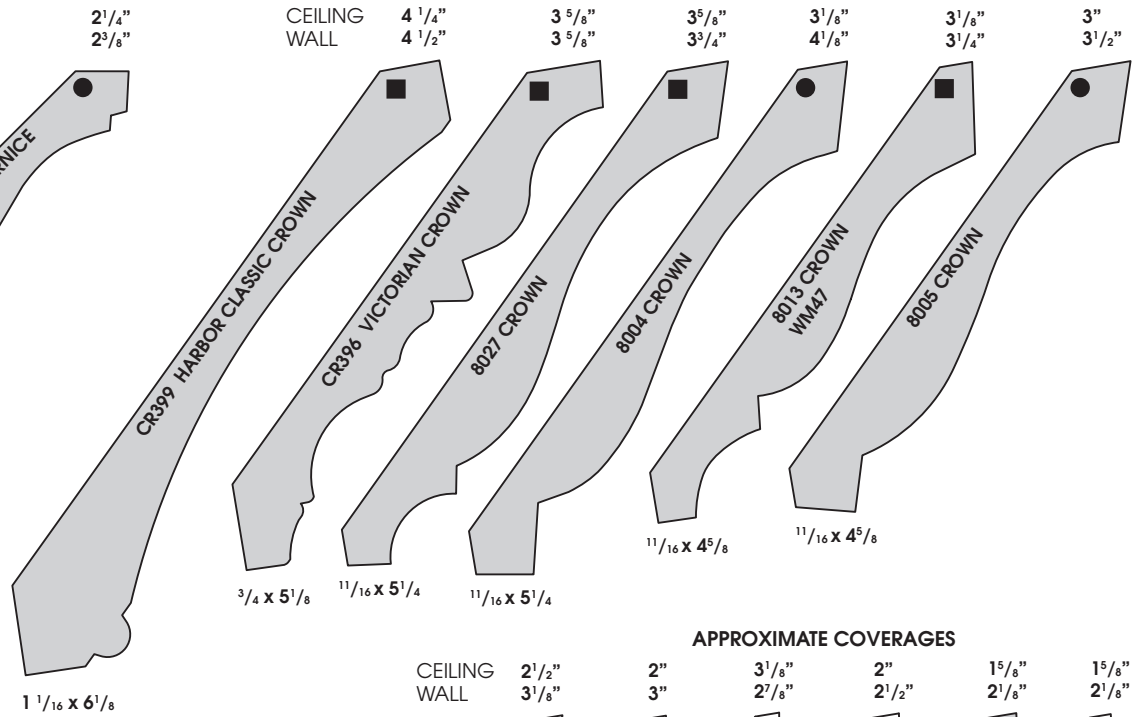

COVE

APPROXIMATE COVERAGES

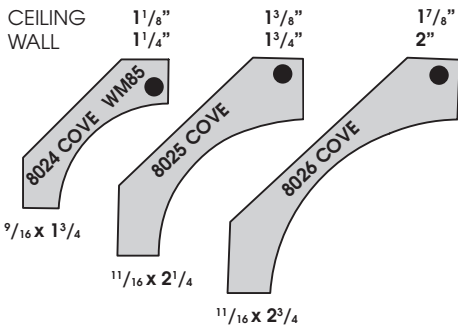

APPROXIMATE COVERAGES

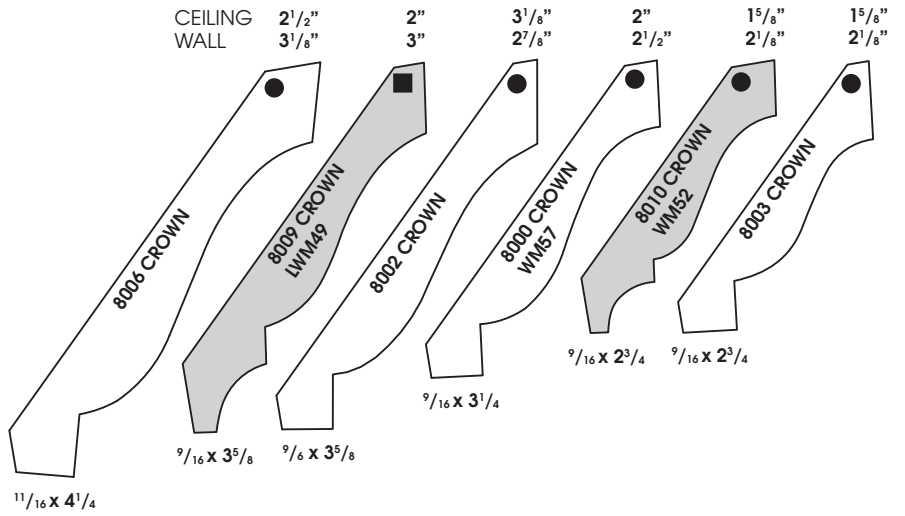

BED

APPROXIMATE COVERAGES

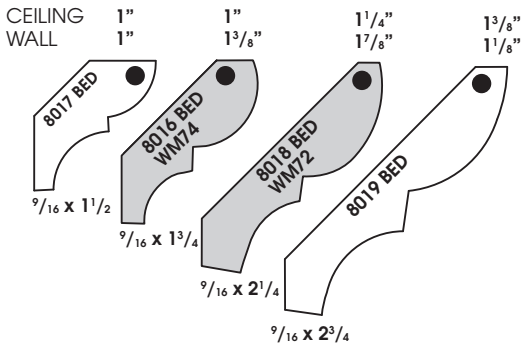

SOLID CROWN

APPROXIMATE COVERAGES

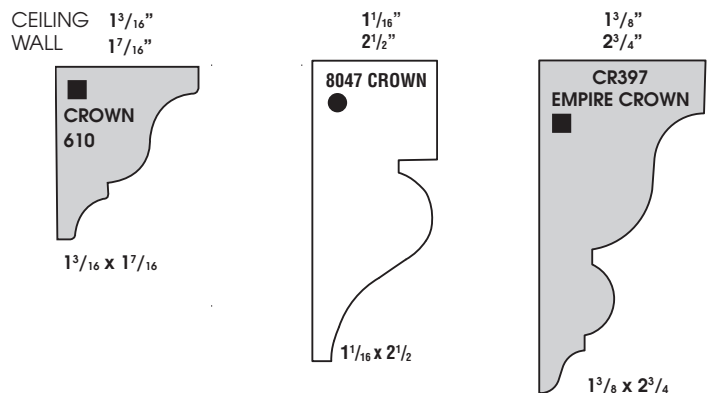

■ = FJP
 ● = CLEAR
 [M] = MDF
 * = FJP + CLEAR
 SHADING = IN STOCK

BASE MOULD

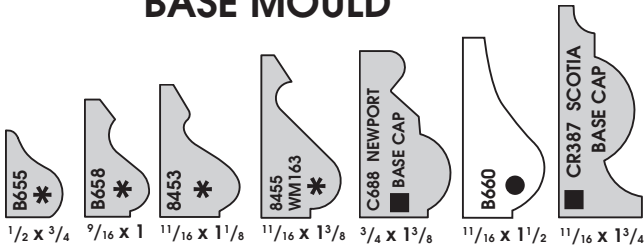

CHAIR RAIL

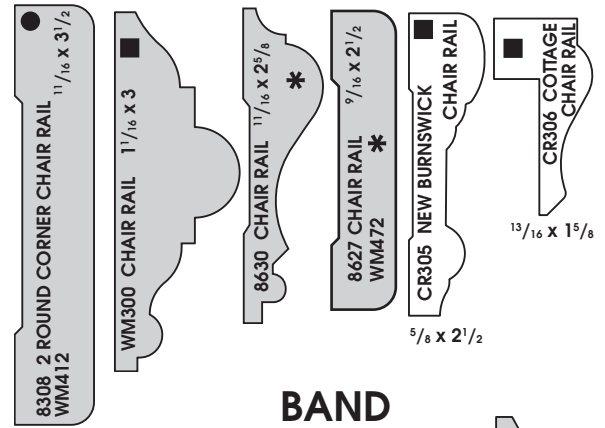

QUARTER ROUND

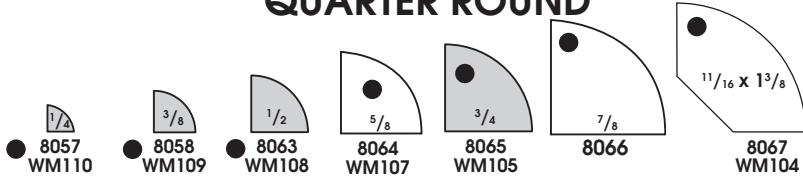

BAND

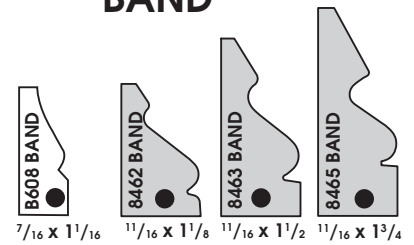

HALF ROUND

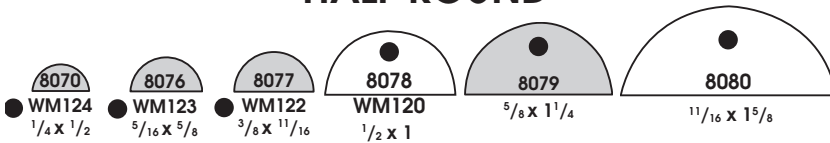

SCOTIA

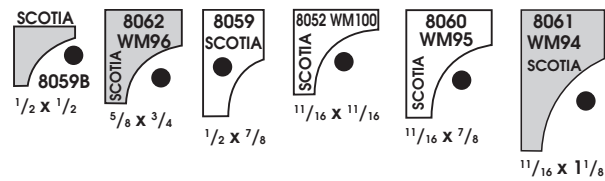

SCREEN STOP

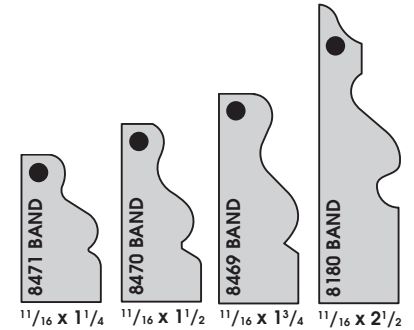

CAP

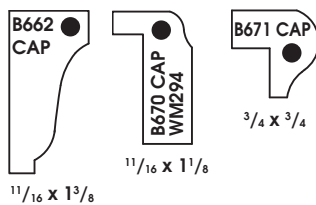

LATTICE

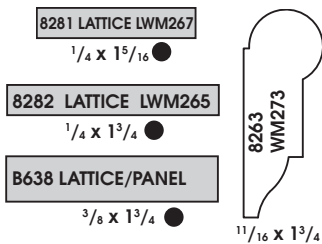

PICTURE

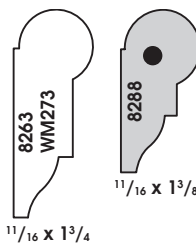

NOSING

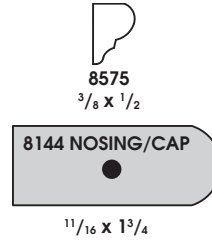

HAND RAIL

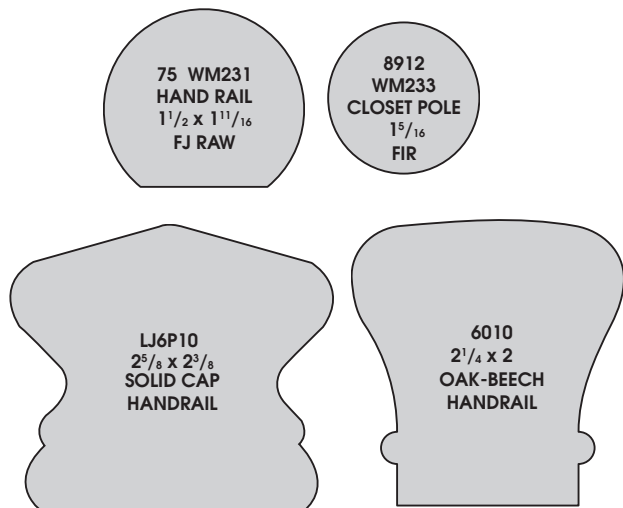

DRIP CAP

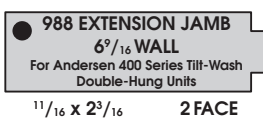
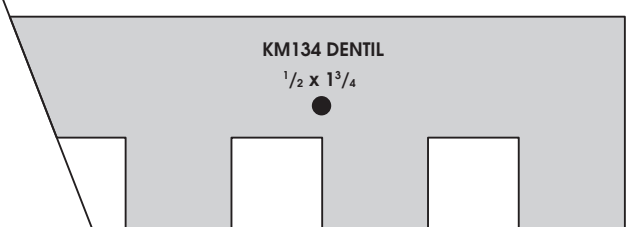
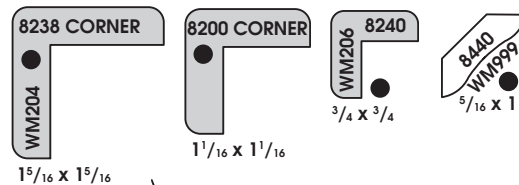
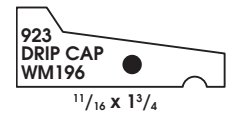

Suggested Crown Combinations Standard Profiles

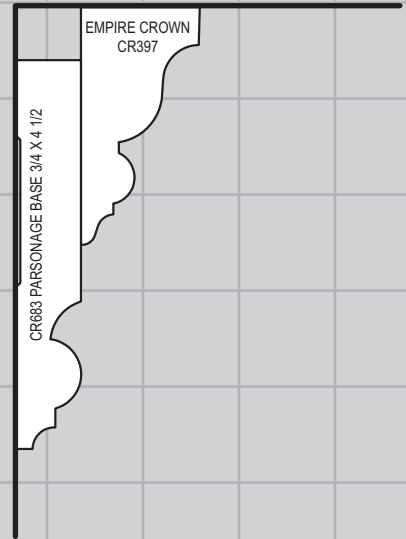
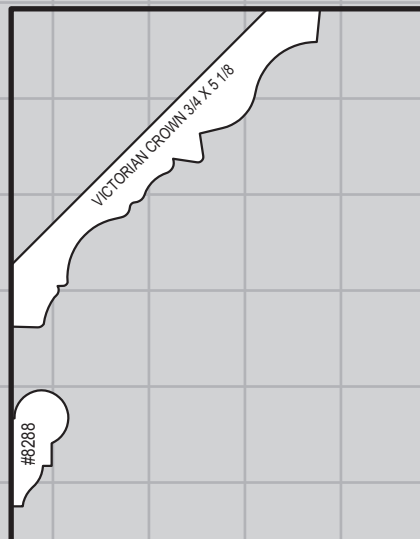
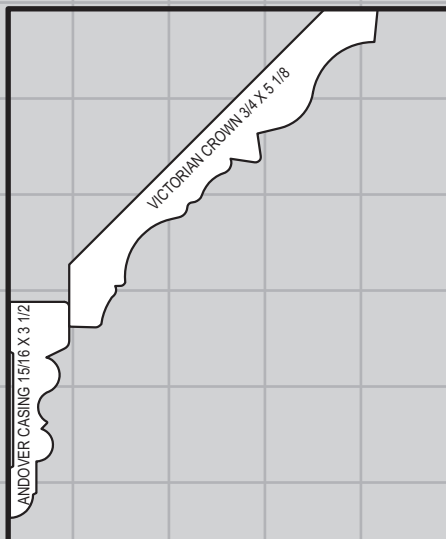
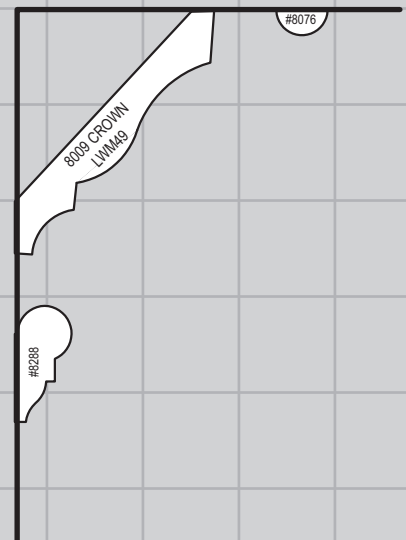
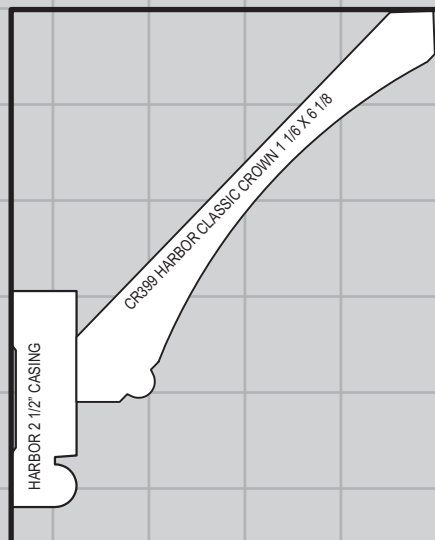
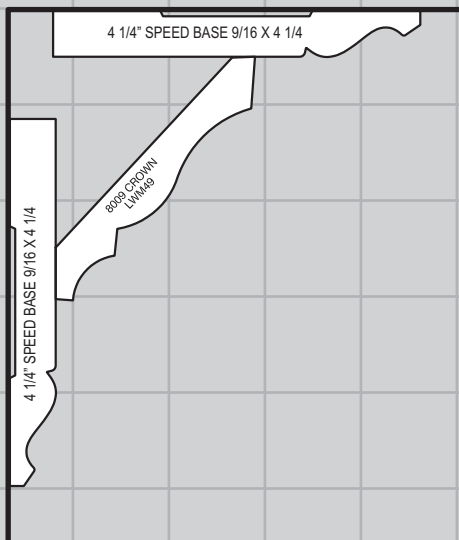
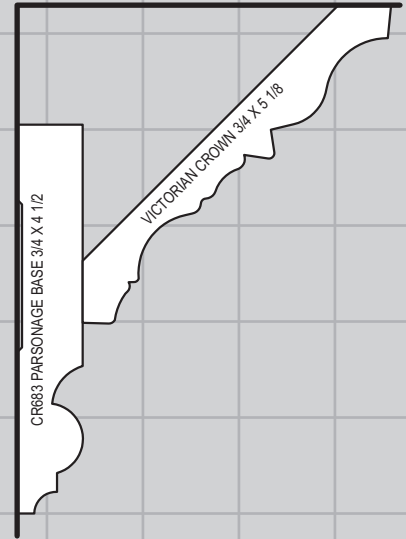
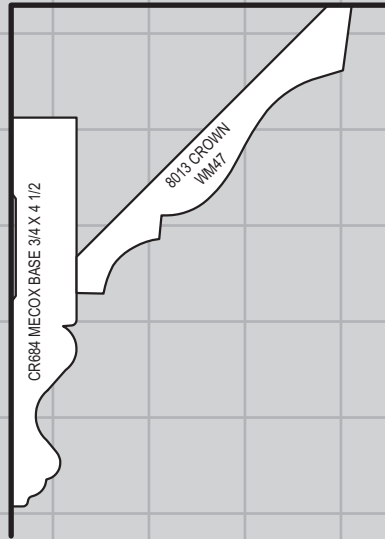
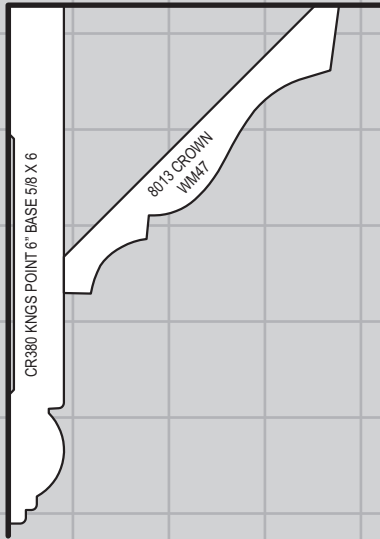

Suggested Combination Head Casing with Side Casing Options

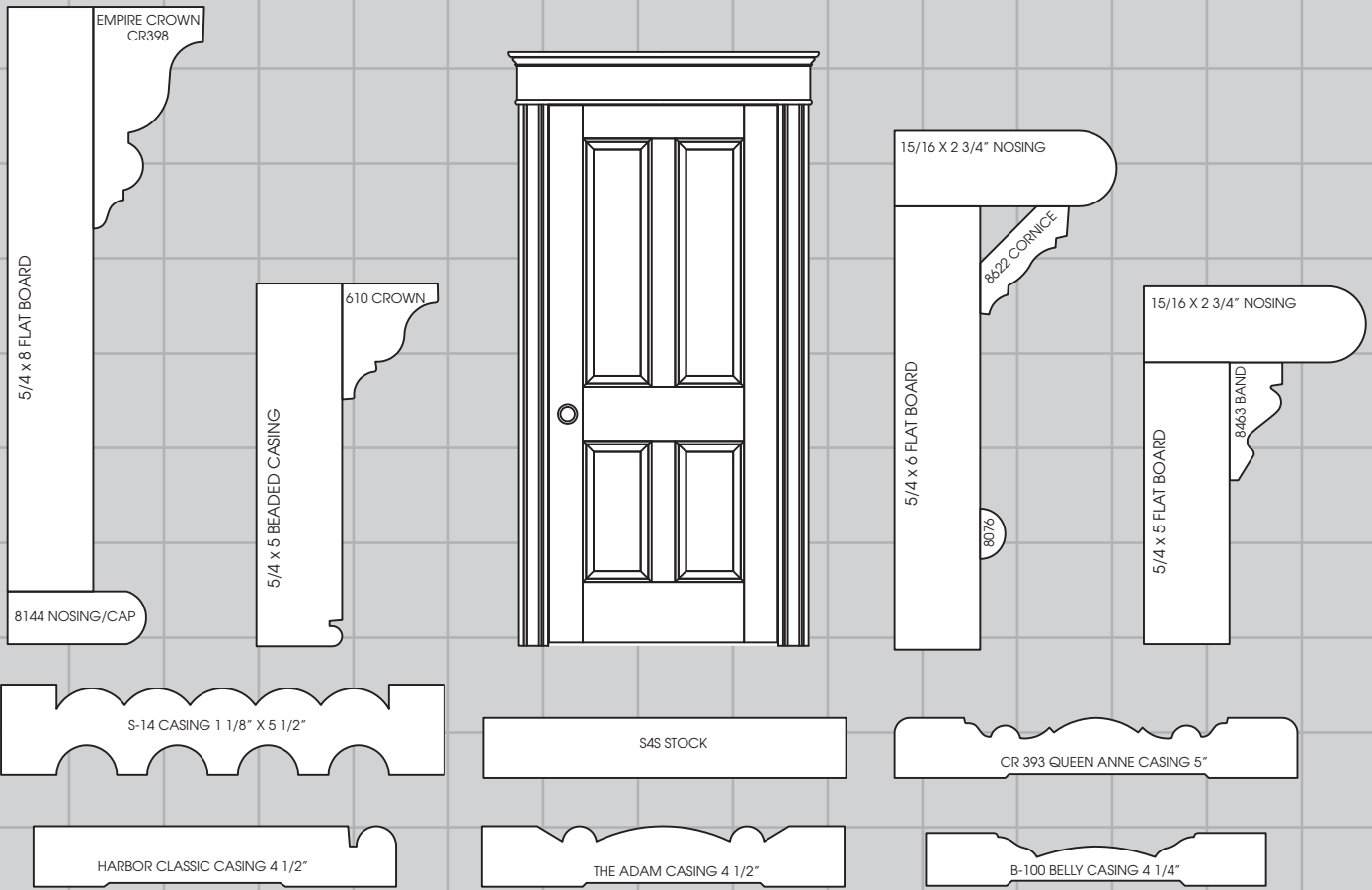

Casing Combinations Standard Profiles

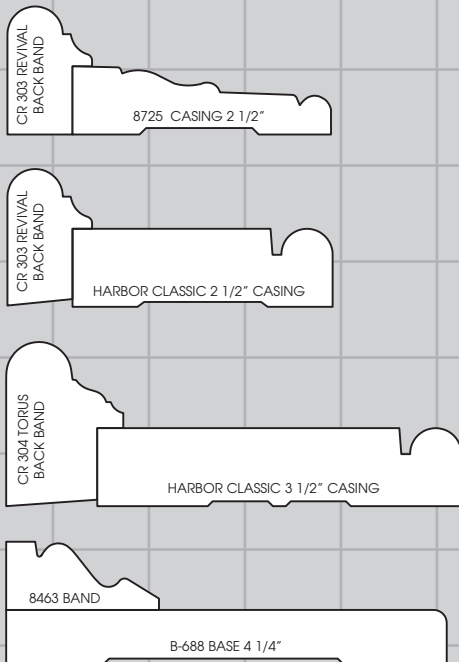

Chair Rail Combinations Standard Profiles

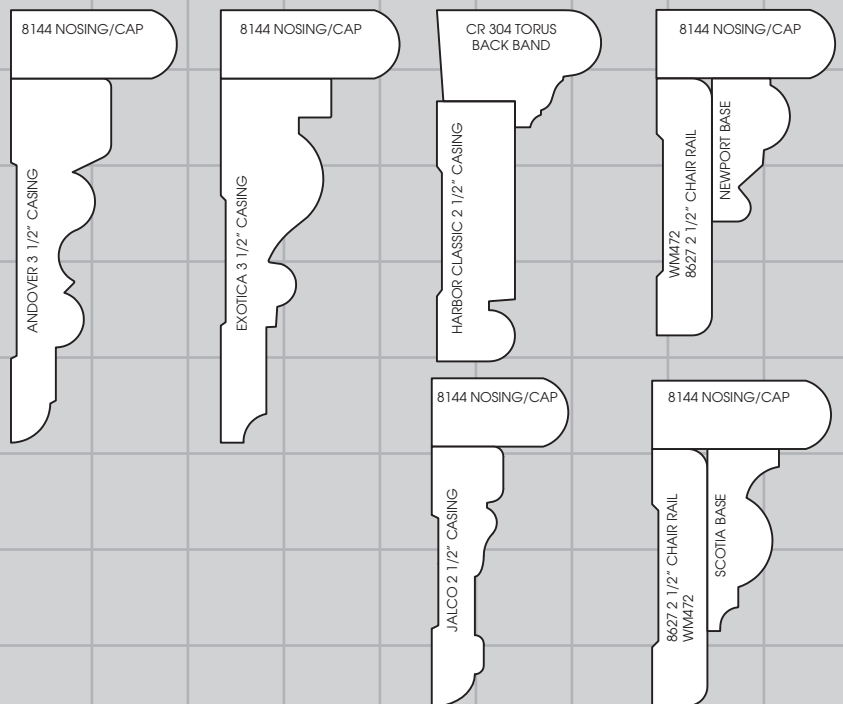

Classical Colonial

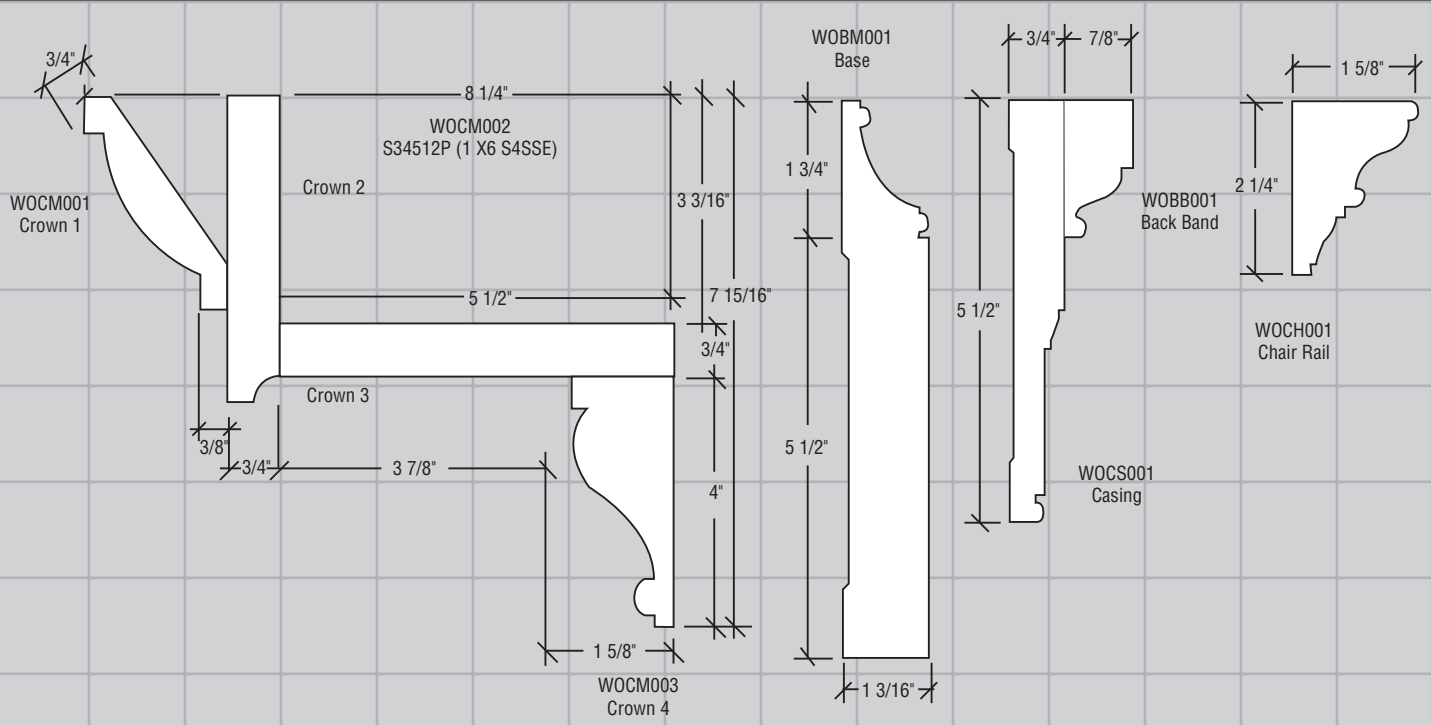

Colonial Revival

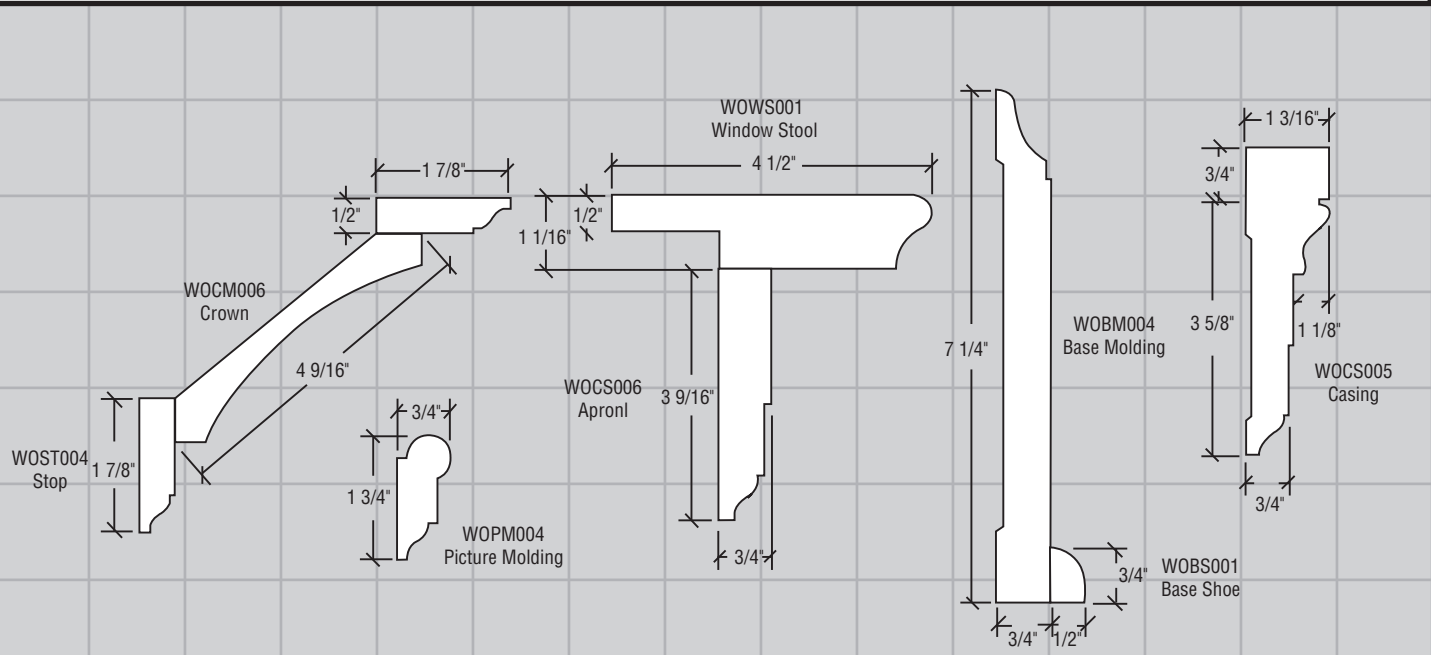

Special Order 3-5 Day Lead Time

Classical Craftsman

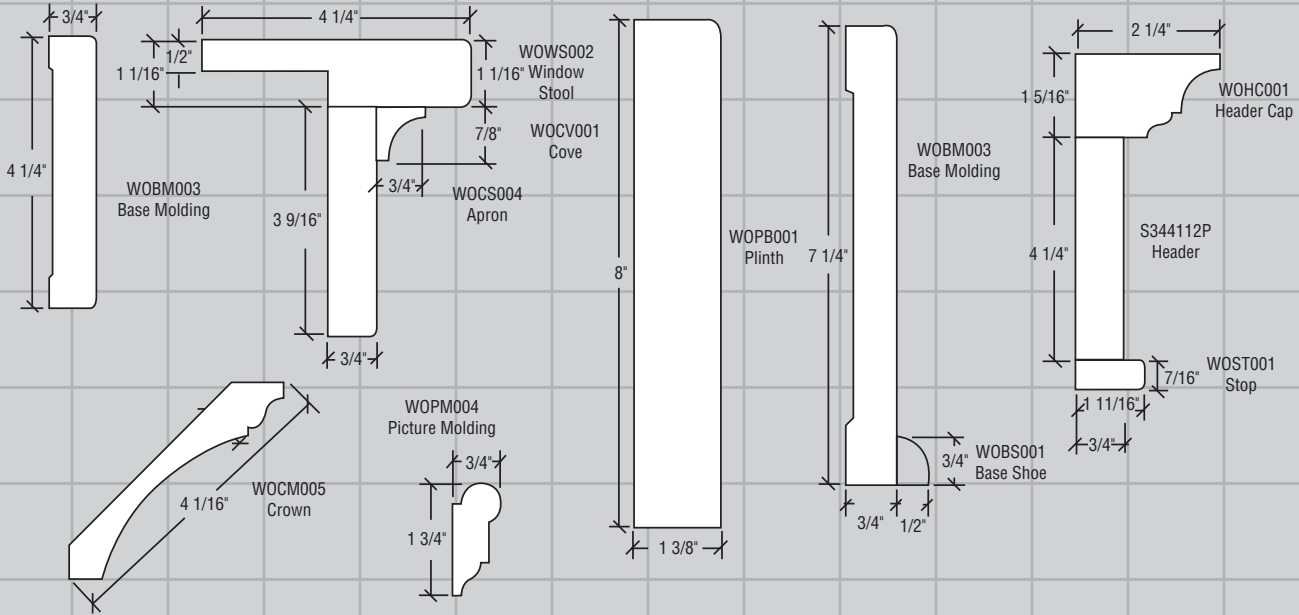

Greek Revival

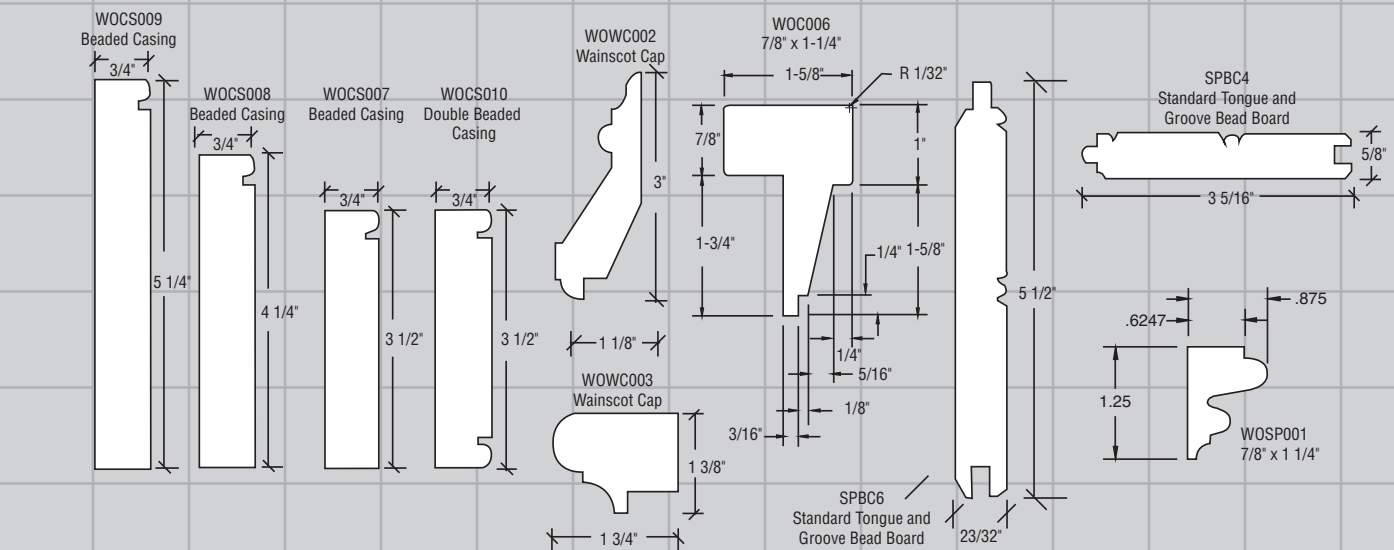
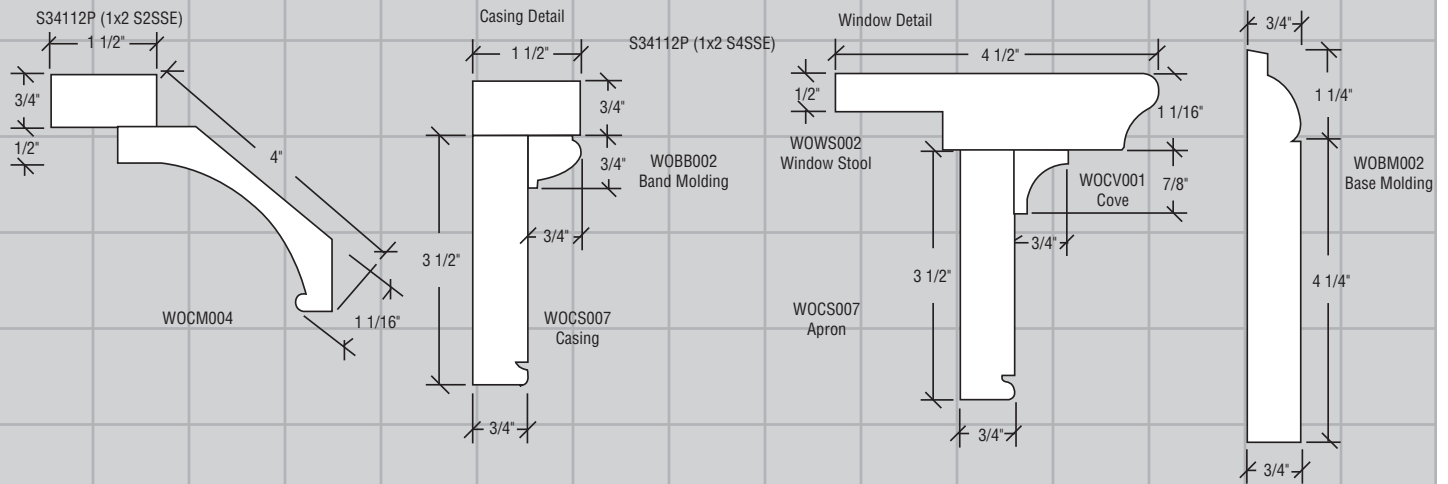

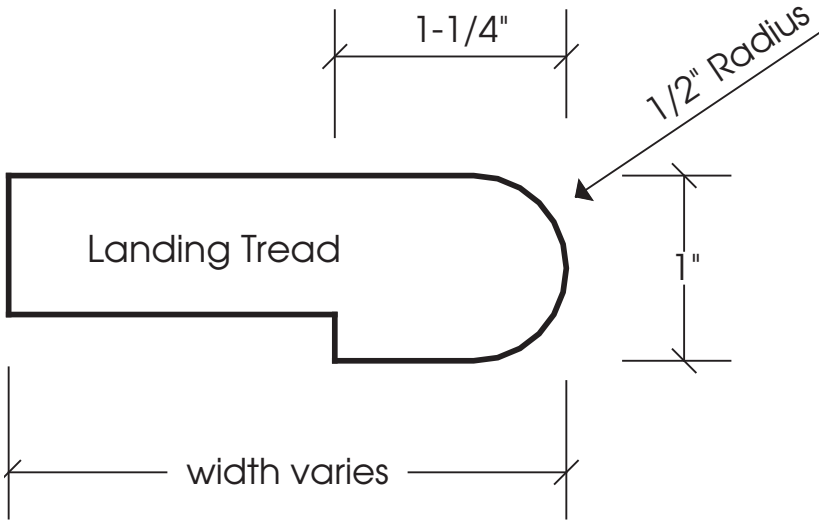

Options for machined edge:

- 1 long side
- 2 long sides
- 1 long side & 1 end
- 1 long side & 2 ends
- 2 long sides and 1 end
- 2 long sides and 2 ends

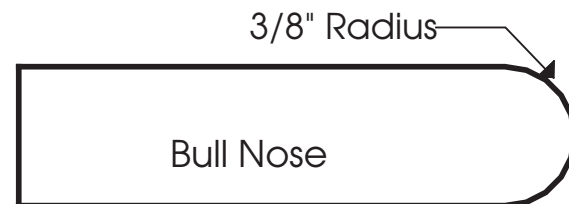
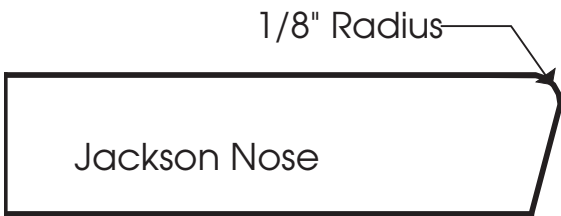

beaded profiles can only be machined on the side